

# PLAYBACK UNITS: (3)

RURAL SAVE GRAIN PROG.

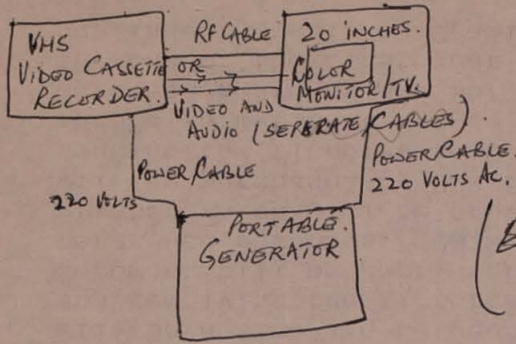

(EXTERNAL AMPLIFIER / SPEAKER AND PORTABLE GENERATOR OF THE A/V VAN CAN BE USED WITH 2 UNITS)

## VHS FIELD RECORDING UNIT

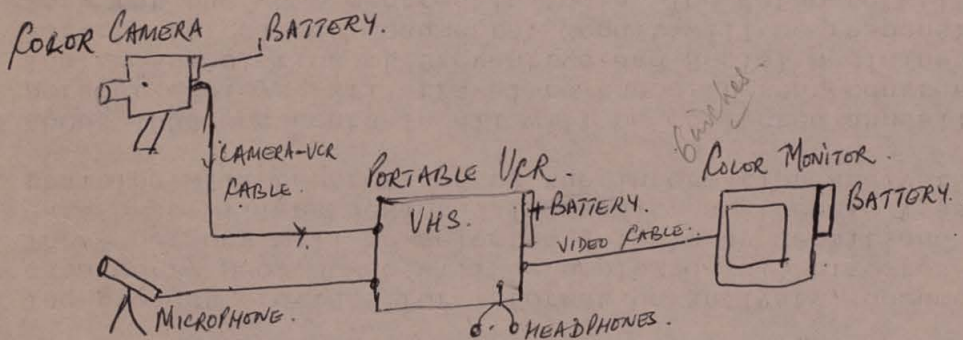

CAMERA and VCR Power adapters for recharging the batteries.

## FIELD RECORDING BY CAMCORDER

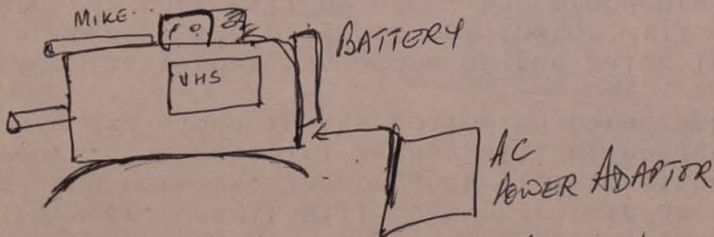

Can use an external mike Headphone.

# VHS Playback Units.

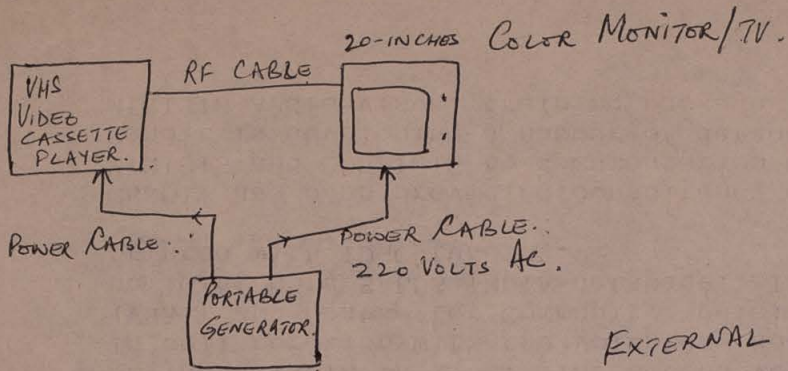

EXTERNAL SPEAKER/AMPLIFIER OPTIONAL

# U-MATIC FIELD RECORDING UNIT.

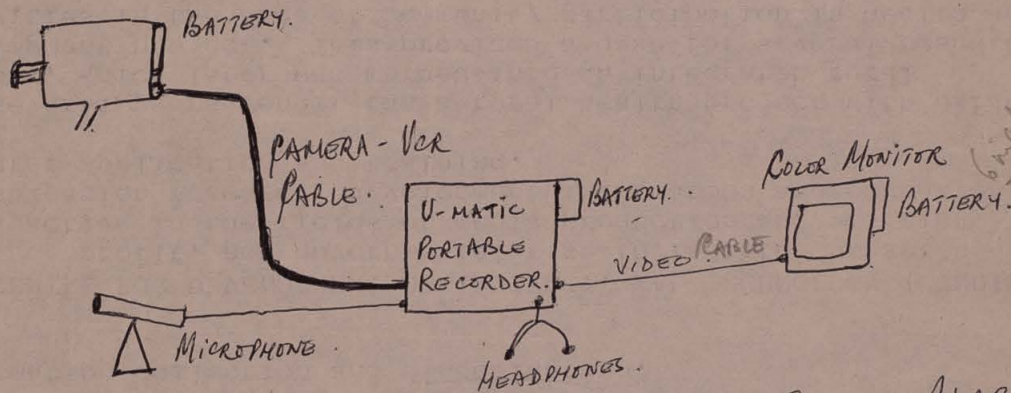

CAMERA / ~~VCR~~ VCR AND MONITOR POWER ADAPTORS FOR RECHARGING THE BATTERIES

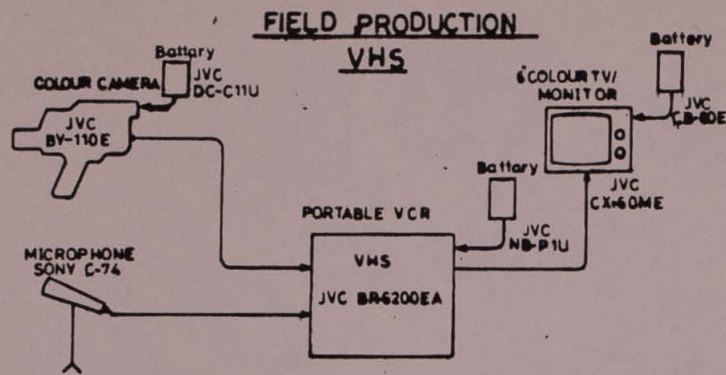

**BY-110E CAMERA ACCESSORIES:**

1 AC Power adaptor  
JVC AA-C11U

**BR-6200EA VHS VCR ACCESSORIES:**

1 AC Power adaptor  
JVC AA-P26 EG



LIGHTING KIT - PORTABLE BATTERY OPERATED  
CINE 60SGK-8304 PS

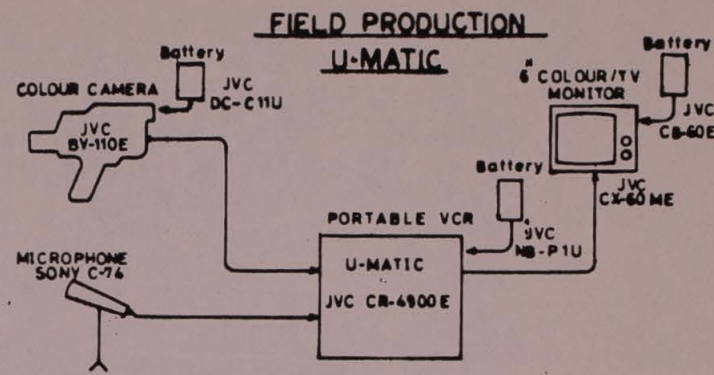

**BY-110E CAMERA ACCESSORIES:**

1 AC Power adaptor  
JVC AA-C11U

**CR-4900E U-MATIC VCR ACCESSORIES:**

1 AC Power adaptor



LIGHTING KIT - PORTABLE BATTERY OPERATED  
CINE 60SGK-8304 PS

**FIELD PRODUCTION**

**VIDEO MOVIE**

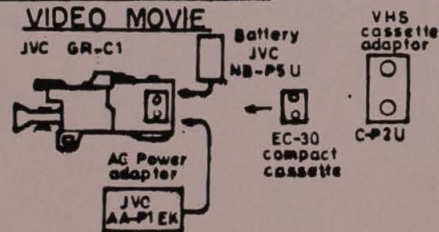

TITLE: FIELD PRODUCTION SYSTEMS (Black Diagram)					
MATERIAL	—	MAIN ASSY		DRAWN	20-8-85
FINISH	—	SUB ASSY		CHKD	
WEIGHT	—	SCALE	N T S	APPD	
PROJECT	PROSHIKA	ALL DIMS IN MM		AMND	
		DRG NO. CV/85/102		PROJECTION	
		SHT 1 OF 1			

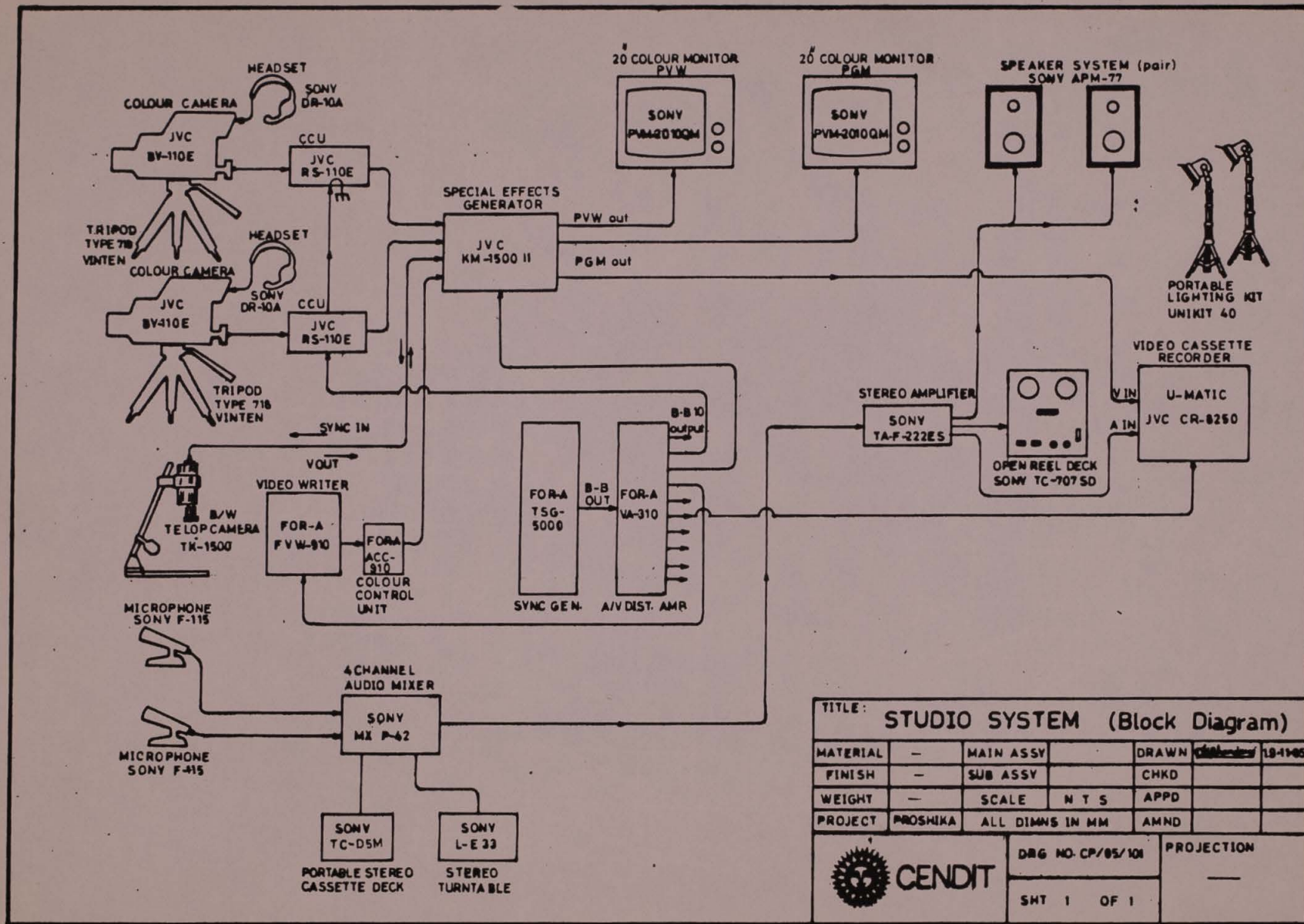

# EDITING SYSTEM

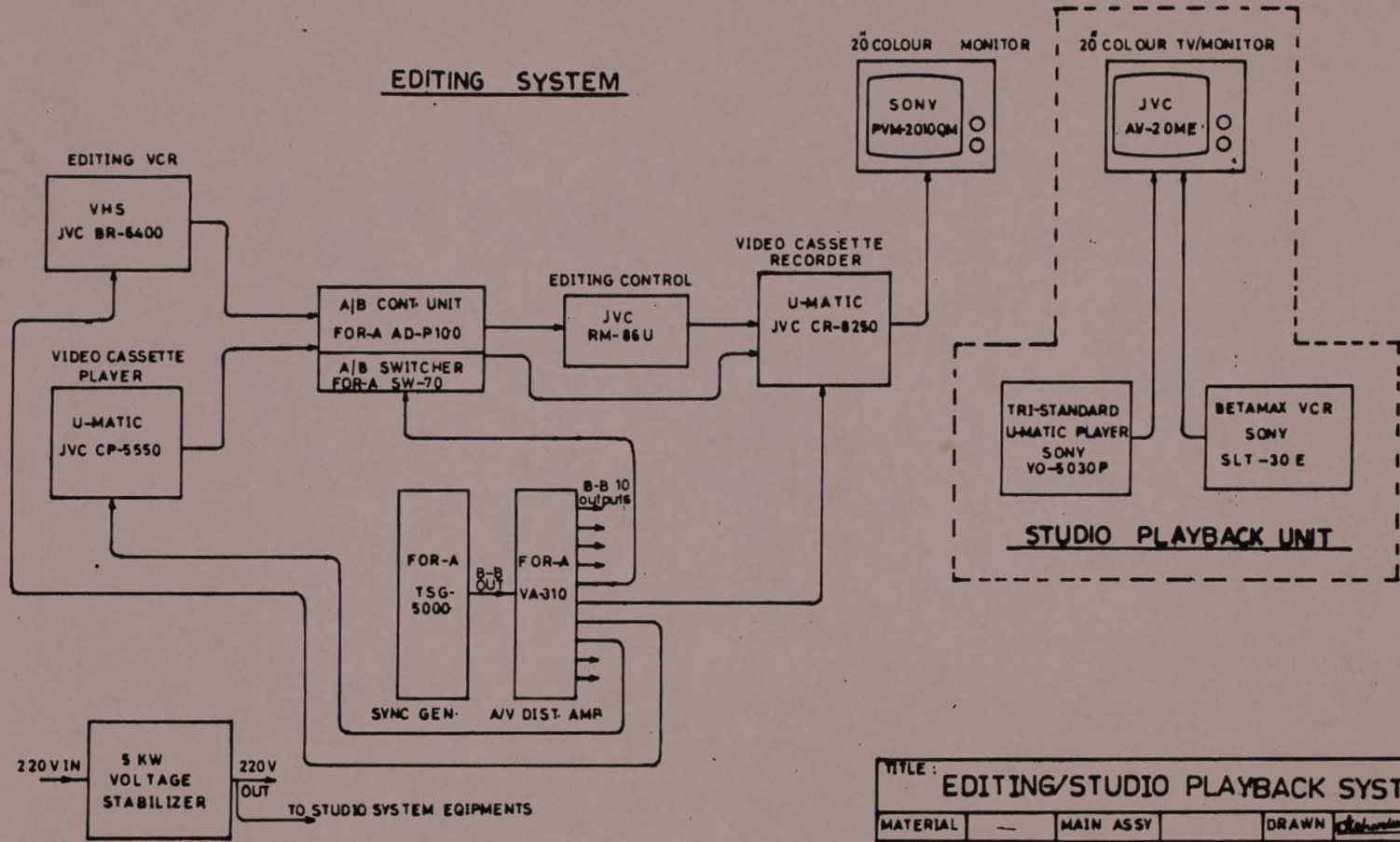

TITLE: **EDITING/STUDIO PLAYBACK SYSTEMS**

MATERIAL	—	MAIN ASSY		DRAWN	<i>[Signature]</i>	251105
FINISH	—	SUB ASSY		CHKD		
WEIGHT	—	SCALE	N T S	APPD		
PROJECT	PROSHKA	ALL DIMNS IN MM		AMND		

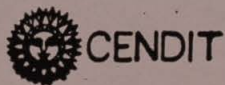

DRG NO. CP/85/103

SHT 1 OF 1

PROJECTION

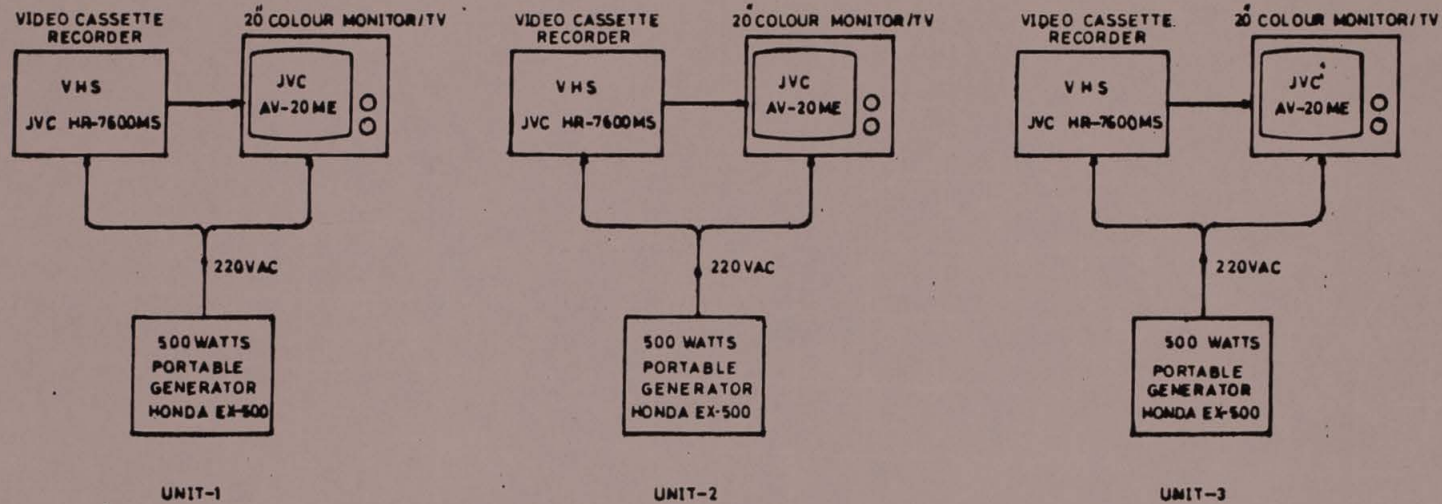

TITLE: PLAYBACK SYSTEMS (Block Diagrams)					
MATERIAL	—	MAIN ASSY		DRAWN	26-11-85
FINISH	—	SUB ASSY		CHKD	
WEIGHT	—	SCALE	N.T.S.	APPD	
PROJECT	PROSHIKA	ALL DIMNS IN MM		AMND	
 <b>CENDIT</b>			DRG NO. CPV 85/104		PROJECTION
			SHT 1 OF 1		